

MOTORES ELÉCTRICOS

EFICIENCIA PREMIUM (IE3)

ALTAMIRA® Serie MAPT2P

•RESIDENCIAL

•INDUSTRIAL

•COMERCIAL

•AGRÍCOLA



EFICIENCIA PREMIUM



AISLAMIENTO CLASE F



MOTOR CERRADO (TCCV)



VOLTAJE DUAL



GRAN ROBUSTES Y ALTA CALIDAD

Certificado bajo la NOM-016-ENER-2016

NOM

En motores desde 1 hasta 100 HP



ESPECIFICACIONES

Los Motores verticales altamira eficiencia premium, están fabricados con los más altos estándares de calidad para asegurar su máximo desempeño.

CARACTERÍSTICAS TÉCNICAS

- Aislamiento: clase F
- Protección: IP 55
- Acoplamiento: IEC
- Voltaje: 3 * 220 ó 440V
- Frecuencia: 60Hz
- Número de polos: 2
- Máx. temperatura ambiente: 50°C

DESCRIPCIÓN DEL CÓDIGO

MAPT2P 1.5 3 234

- SERIE
- Potencia nominal del motor
- Número de fases
- Voltaje Dual: 220 ó 440

DIMENSIONES

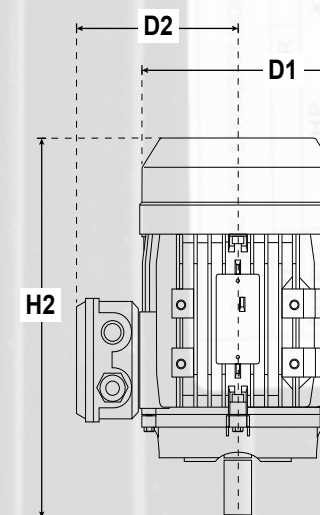

LOS MOTORES SON DE EJE SÓLIDO, NO REQUIEREN CUÑA.

TABLA DE ESPECIFICACIONES

CÓDIGOS		MAPT2P 1/23234	MAPT2P 3/43234	MAPT2P 13234	MAPT2P 1.53234	MAPT2P 23234	MAPT2P 33234	MAPT2P 43234	MAPT2P 5.53234	MAPT2P 7.53234	MAPT2P 103234	MAPT2P 153234	MAPT2P 203234	MAPT2P 253234	MAPT2P 303234	MAPT2P 403234	MAPT2P 503234	MAPT2P 603234	MAPT2P 753234	MAPT2P 1003234	
POTENCIA	HP	1/2	3/4	1	1.5	2	3	4	5.5	7.5	10	15	20	25	30	40	50	60	75	100	
	KW	0.37	0.55	0.75	1.1	1.5	2.2	2.9	4	5.5	7.4	11	15	18.5	22	30	37	45	55	75	
VOLTAJE		220/440																			
AMPERAJE A PLENA CARGA		1.7 / 1.0	2.4 / 1.4	3.1 / 1.8	4.0 / 2.0	5.7 / 3.1	8.1 / 4.2	11.1 / 5.6	14.3 / 7.6	19.2 / 9.8	25.4 / 12.8	37 / 19.6	48.5 / 23.5	59.7 / 28.5	70.4 / 33.8	95.7 / 47.9	117.3 / 58.7	141.8 / 70.9	173.3 / 86.6	235 / 117.5	
VELOCIDAD (RPM)		3 470			3 510	3 505	3 500	3 548	3 510	3 546	3 545	3 542	3 538	3 569			3 540		3 560	3 550	3 560
EFICIENCIA %		77.2	79.9	83.9	85.1	82.1	89.2	89.4	89.5	89.0	91.5	90.75	90.5	92.6	93.3	92.4	93.0	93.6	93.6	94.1	
ARMAZÓN		71A	71B	80A	80B	90S	90L	100L	112M	132S		160M	160M	160L	180M	200L		225M	250M	280S	
BRIDA		B14									B5										
POSICIÓN		DIMENSIONES Y PESOS																			
D1 (mm)		141			177			197	220	235			269			318	390		446	485	550
D2 (mm)		115			141			147	161	197			215			241	295	295	325	355	410
H2 (mm)		225		275	329	345		378	385	440	485	555	600	650		770		800	910	985	
PESO (kg)		5.8	6.9	7.9	14.3	17.3	20.3	26.6	32.5	48.6	55.3	79.4	93	125	138	246	267	353	408	548	